

# **DAIHATSU**

# **F300**

[HD-Engine]

## **IGNITION SYSTEM**

PRECAUTIONS .....	IG- 2
TROUBLE SHOOTING .....	IG- 2
IGNITION SYSTEM OUTLINE .....	IG- 3
DISTRIBUTOR .....	IG-15
SST [Special Service Tools] .....	IG-31
TIGHTENING TORQUE .....	IG-31
SPECIFICATION .....	IG-31

WPES0-IG001

## IGNITION SYSTEM

### PRECAUTIONS

1. Do not leave the ignition key switch turned ON for more than ten minutes while the engine is stopped.
2. When a tachometer is connected to the system, connect the test probe of the tachometer to the negative (-) terminal of the ignition coil.
3. As some tachometers are not compatible with this ignition system, it is recommended to confirm the compatibility of your unit before using.
4. Never allow the ignition coil terminals to touch ground. It could result in damage to the ignitor and/or the ignition coil.
5. Do not disconnect the battery cable when the engine is running.
6. Make sure that the igniter is properly grounded to the body.

WFES0-IG002

### TROUBLE SHOOTING

Problem	Possible causes	Remedies	Page
Engine will not start/hard to start. (Engine crank normally.)	Incorrect ignition timing	Reset timing.	IG-28
	Ignition coil faulty	Inspect coil.	IG-14
	Igniter faulty		
	Distributor faulty	Inspect distributor.	IG-16
	Spark plug wires faulty	Inspect spark plug wires.	IG-11
	Spark plugs faulty	Inspect plugs.	IG-12
Rough idle or engine stalls.	Ignition wiring disconnected or broken	Inspect wiring.	
	Spark plugs faulty	Inspect plugs.	IG-12
	Ignition wiring faulty	Inspect wiring.	
	Incorrect ignition timing	Reset timing.	IG-28
	Ignition coil faulty	Inspect coil.	IG-14
	Igniter faulty		
Engine hesitation/poor acceleration	Distributor faulty	inspect distributor.	IG-16
	Spark plug wires faulty	Inspect spark plug wires.	IG-11
	Spark plugs faulty	Inspect plugs.	IG-12
Engine dieseling (Engine runs after ignition switch is turned OFF.)	Ignition wiring faulty	Inspect wiring.	
	Incorrect ignition timing	Reset timing.	IG-28
Muffler explosion (after fire) all the time	Incorrect ignition timing	Reset timing.	IG-28
Engine backfire	Incorrect ignition timing	Reset timing.	IG-28
Poor fuel economy	Spark plugs faulty	Inspect plugs.	IG-12
	Incorrect ignition timing	Reset timing.	IG-28
Engine overheating	Incorrect ignition timing	Reset timing.	IG-28

WFES0-IG003

### IGNITION SYSTEM OUTLINE

#### IGNITION SYSTEM CIRCUIT

The ignition system employs a full-transistorized, battery ignition type.

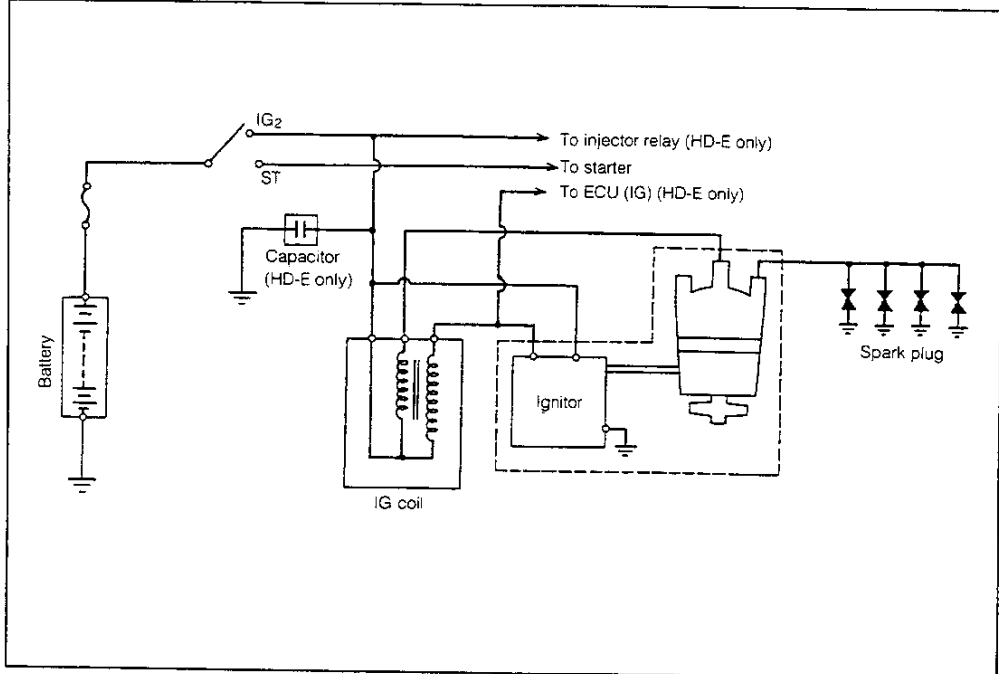

WFE90-IG004

## IGNITION SYSTEM

### DISTRIBUTOR

The distributor is a full-transistorized type which incorporates a signal generator and an ignitor.

The signal generator consists of a signal rotor, a magnet and a pickup coil. The ignition signal is obtained electrically by the rotation of the signal rotor.

This type of distributor has no contact point. Since there is no problem attributable to contact points, no maintenance is required relating to contact points.

As for the timing advance device, the distributor is equipped with a two-stage vacuum timing advance device and a governor timing advance device.

A high-voltage terminal is protruded laterally.

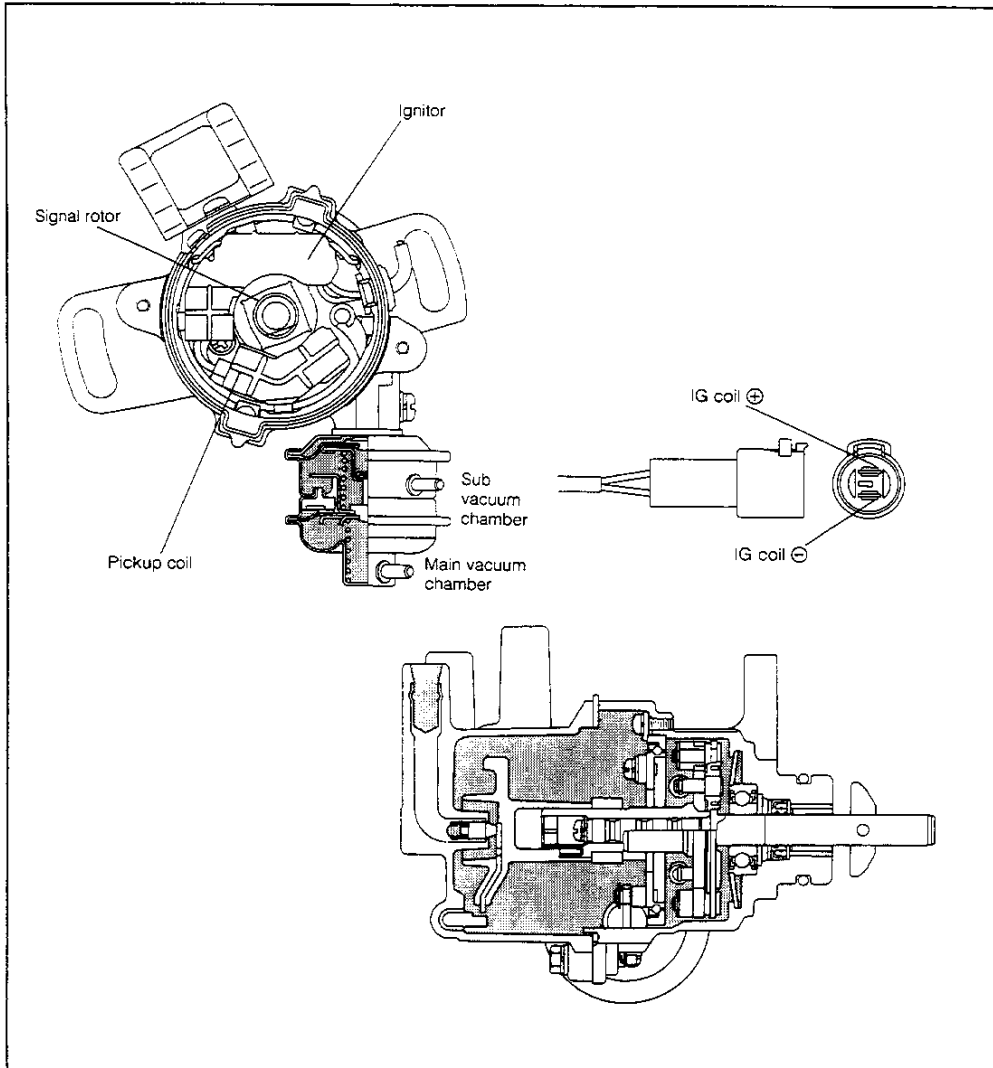

WFES0-IG005

**SPECIFICATIONS**

[HD-C Engine]

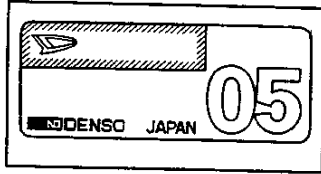

**Vacuum controller negative pressure circuit**

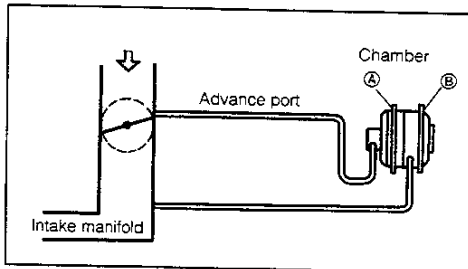

**Wiring diagram**

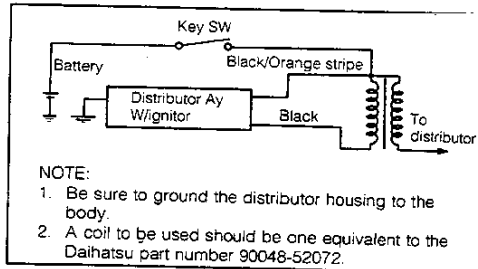

**Timing advance characteristics**

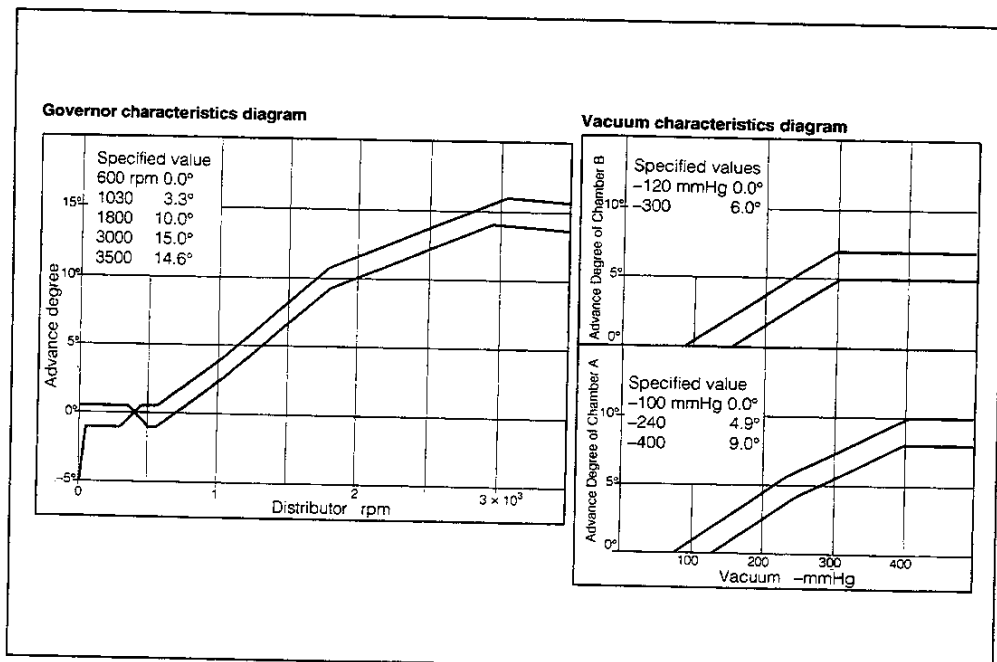

WFE90-IG006

# IGNITION SYSTEM

## [HD-E Engine] (General specifications)

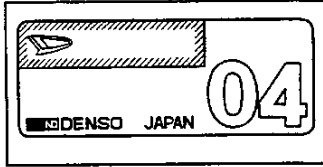

### Vacuum controller negative pressure circuit

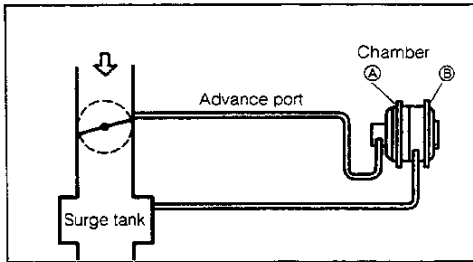

### Wiring diagram

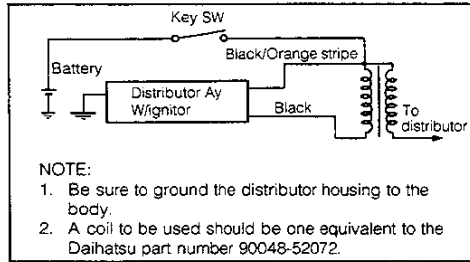

### Timing advance characteristics

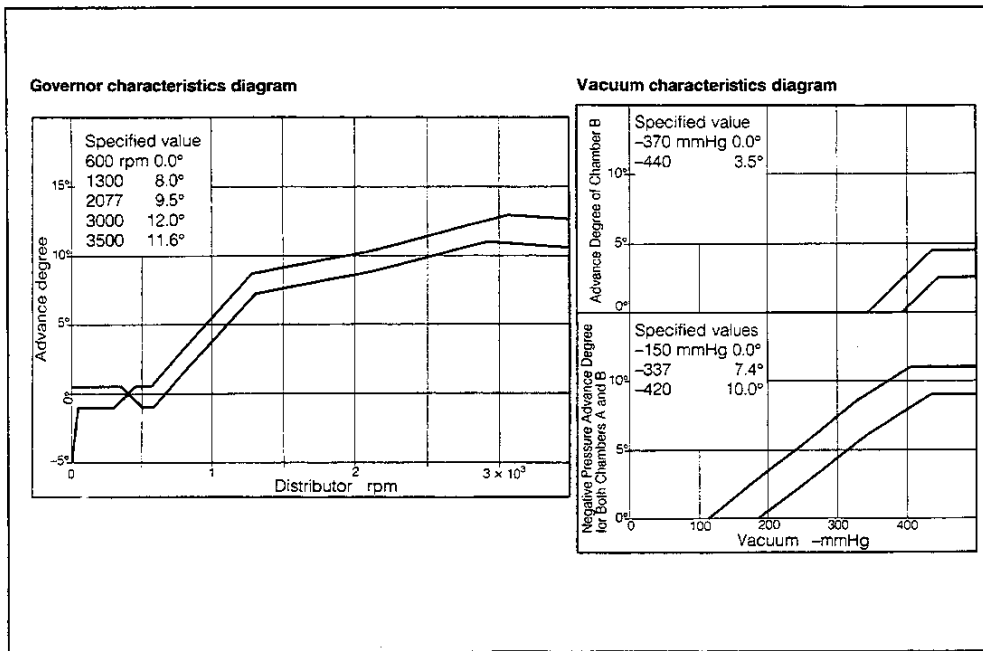

WFEB0-IG007

[HD-E Engine] (U.S. specifications)

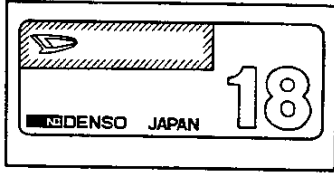

Vacuum controller negative pressure circuit

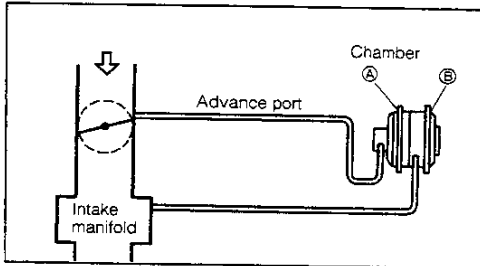

Wiring diagram

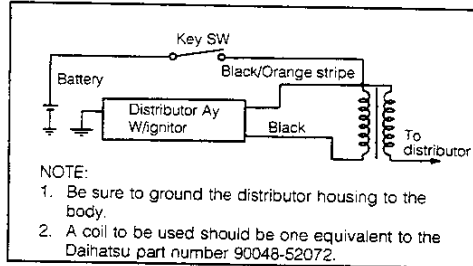

- NOTE:
1. Be sure to ground the distributor housing to the body.
  2. A coil to be used should be one equivalent to the Daihatsu part number 90048-52072.

Timing advance characteristics

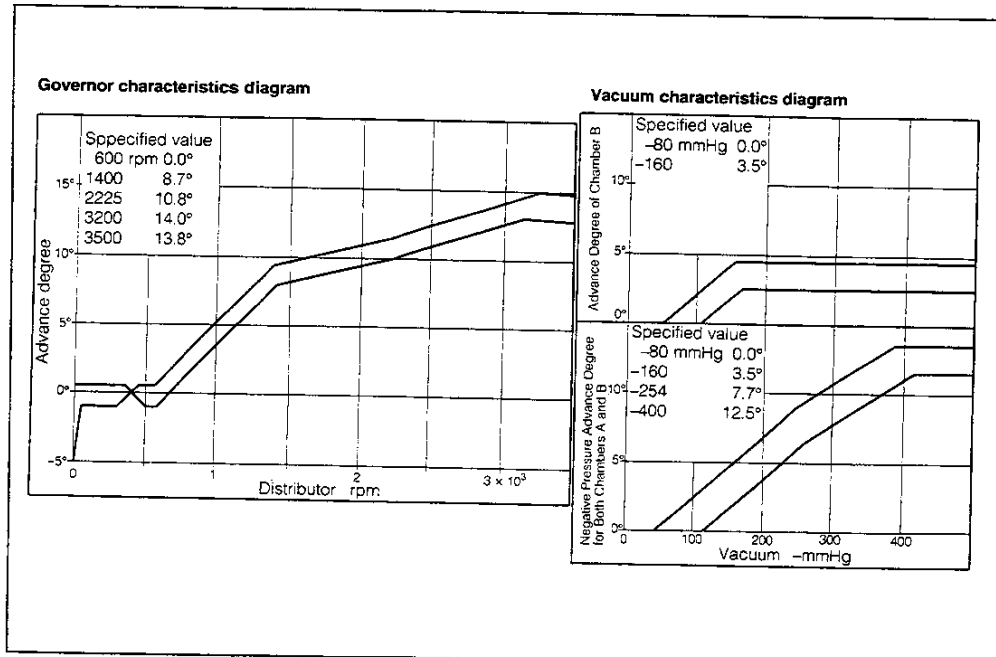

WFE90-IG008

## IGNITION SYSTEM

### IGNITION TIMING CONTROL SYSTEM

#### [HD-C Engine]

The sub timing advance is carried out during the idling operation so that the engine idling may be stabilized. When the engine revolution speed rises, negative pressure starts to be applied to the main diaphragm side. Thus, the ignition timing advances further to an optimum setting. In addition, a VTV provided at the main side delays the transmission of negative pressure so that the ignition timing may be retarded during the acceleration period. Consequently, the combustion temperature is lowered, thereby reducing the NOx and HC emissions.

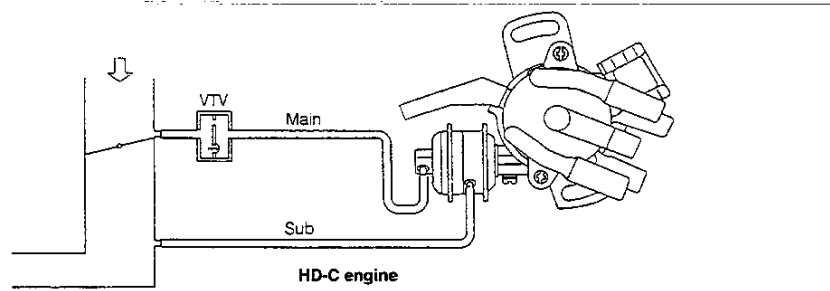

#### [HD-E Engine]

Like Type HD-C engine, Type HD-E engine also employs a system which conducts a two-stage vacuum timing advance and governor timing advance.

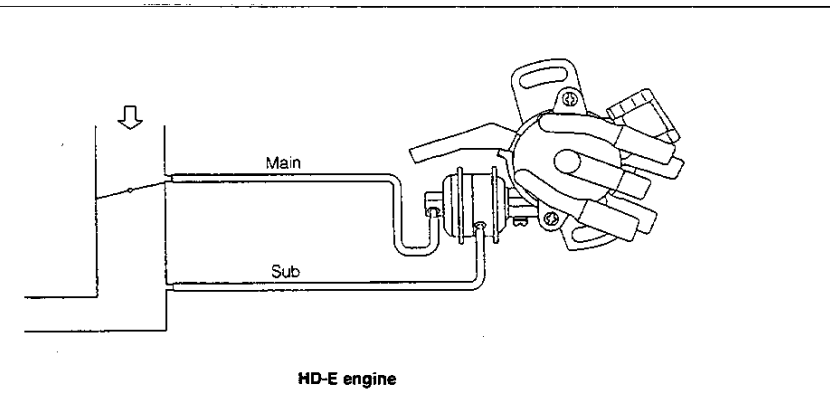



## IGNITION SYSTEM

### SPARK PLUG

The spark plug is a resistor-incorporated, compact spark plug whose width across flats of the hexagon section is 16 mm.

#### Recommended spark plugs

	HD-C · HD-E Engine		
Manufacturer	NIPPONDENSO	NGK	CHAMPION
Type	K20PR-U11	BKR6E-11	RC9YC4
	K22PR-U11	BKR7E-11	RC7YC4
Spark plug gap (mm)	1.0 - 1.1		

### IGNITION COIL

The ignition coil employs a closed core coil which features light weight and compact design.

The closed core coil features high energy conversion efficiency because its magnetic flux circuit is closed owing to an iron core, thus keeping leakage flux to a minimum level.

#### Ignition coil specifications

Primary Coil Resistance: 1.35 - 1.65  $\Omega$   
Secondary Coil Resistance: 22 - 30 k $\Omega$

### IN-VEHICLE INSPECTION

#### Spark test

(Check to see if spark occurs.)

1. Turn OFF the ignition key switch.
2. Disconnect the fuel pump relay and injector relay from the relay box. (Only for HD-E Engine)
3. Connect a timing light to the resistive cord between the distributor and the ignition coil.

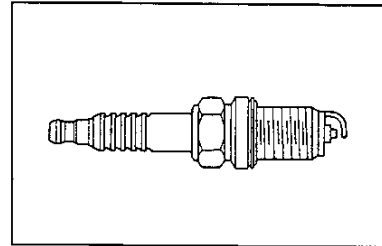

WPES0-IG011

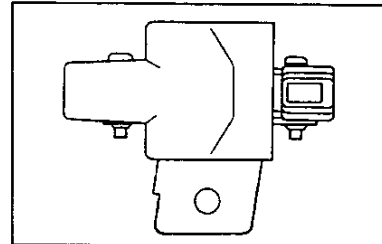

WPES0-IG012

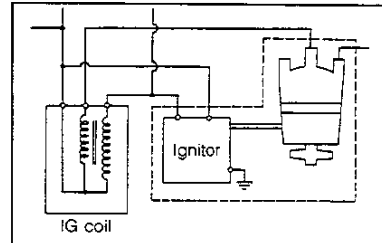

WPES0-IG013

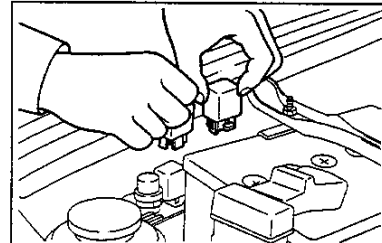

WPES0-IG014

WPES0-IG015

## IGNITION SYSTEM

4. Ensure that the timing light flashes while the engine is being cranked by the starter motor.

If the timing light flashes, check the resistive cords and spark plug.

If the timing light will not flash, perform the check according to the chart given below.

**NOTE:**

- After completion of the inspection, reconnect the fuel pump relay and injector relay to the relay box.

WFES0-IG016

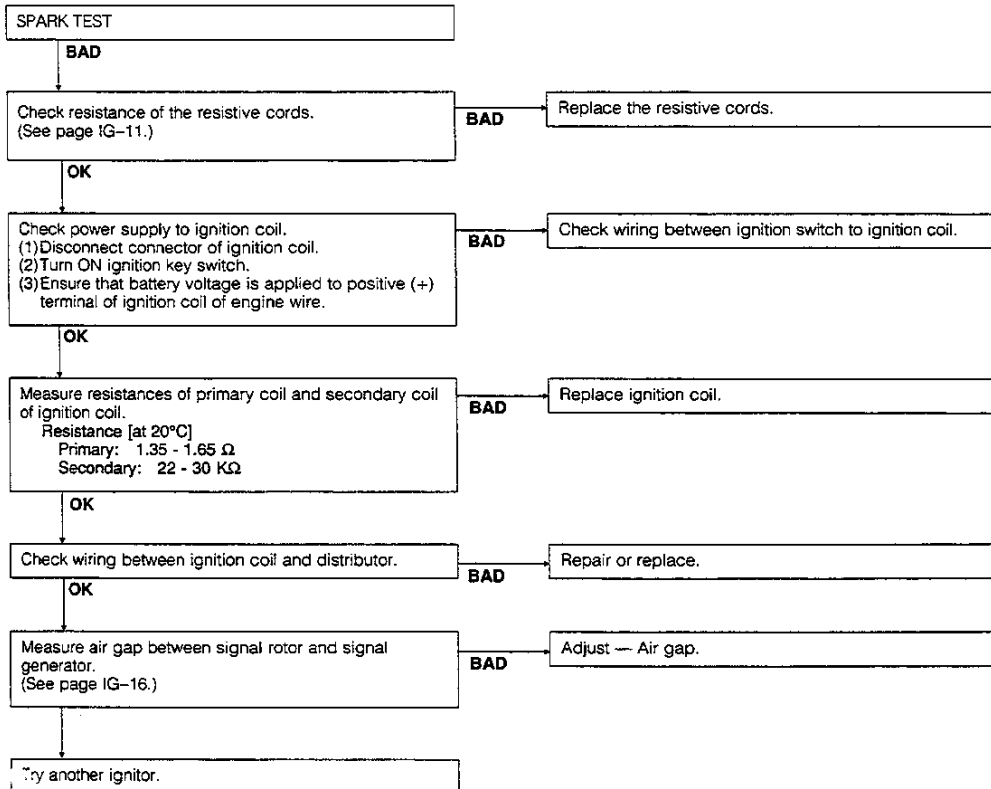

WFES0-IG017

**INSPECTION OF SPARK PLUG WIRE**

1. Remove the air intake chamber.  
(HD-E Engine only)  
(See page EM-17.)
  
2. Carefully remove the spark plug wires from the spark plugs and ignition coil by holding their rubber boots.  
**CAUTION:**
  - Do not hold the cord portion or bend the cord.  
Otherwise, the conductor inside the cord may be damaged.
  
3. Disconnect the distributor connector from the connector clamp.
4. Remove the distributor cap.

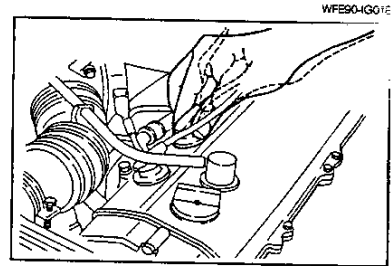

WFE90-IG019

WFE90-IG020

5. Inspection of resistance of spark plug wire and distributor cap terminal  
Maximum Resistance: 15 k $\Omega$

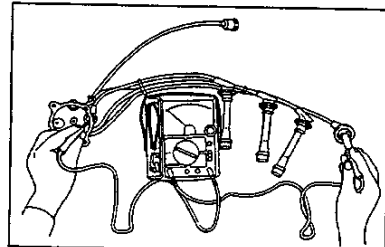

WFE90-IG113

If the resistance exceeds the maximum limit, check the distributor cap terminals.  
Replace the spark plug wire and/or distributor cap, as required.

6. Install the distributor cap with distributor cap gasket interposed.  
**NOTE:**
  - If the distributor gasket is damaged, replace it with a new one.

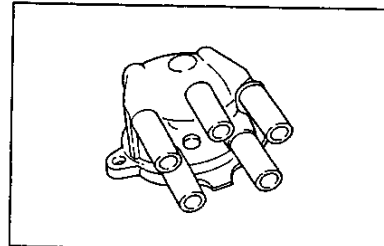

WFE90-IG022

## IGNITION SYSTEM

7. Connect the spark plug wires to the spark plugs and ignition coil.
8. Install the air intake chamber.  
(HD-E engine only)

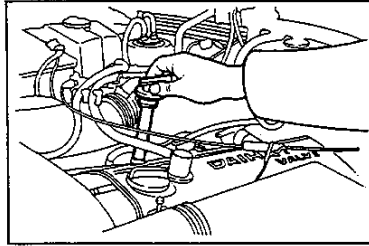

WFES0-IG023

### INSPECTION OF SPARK PLUG

1. Carefully remove the spark plug wire from the spark plugs by holding their rubber boots.
2. Inspection of electrode

- (1) When a megger (Insulation resistance meter) is used:  
Measure the insulation resistance of the spark plug.  
Minimum Insulation Resistance: 15 MΩ

If the measured insulation resistance is less than 15 MΩ, proceed to the step 3.

- (2) When a megger is not available:

- ① Start the engine. Warm up the engine completely.
- ② Race the engine at 4000 rpm for five seconds.
- ③ Remove the spark plug, using the following SST.  
SST: 09268-87703-000

#### WARNING:

- Since the spark plugs are hot, care must be exercised to avoid getting scalded.

- ④ Visually inspect the spark plug.  
If the electrode is dry: Satisfactory  
If the electrode is wet: Proceed to the step 4.

3. Removal of spark plug  
Remove the spark plug, using the following SST.  
SST: 09268-87703-000

4. Visual inspection of spark plug  
Visually inspect the spark plug for electrode wear, thread or insulator damage.  
Replace the spark plug if it exhibits damage.

#### Recommended Spark Plug

CHAMPION	NIPPONDENSO	NGK
RC9YC4	K20PR-U11	BKR6E-11
RC7YC4	K22PR-U11	BKR7E-11

#### NOTE:

- All four spark plugs should have the same heat range and be ones manufactured by the same manufacturer.

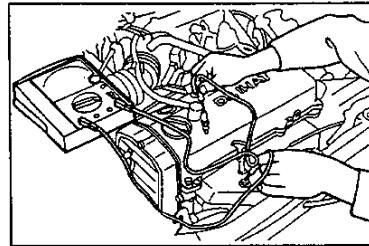

WFES0-IG024

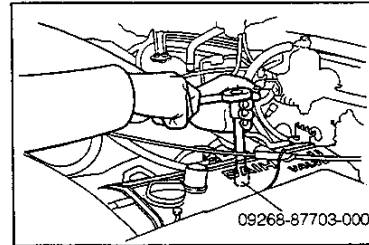

09268-87703-000

WFES0-IG025

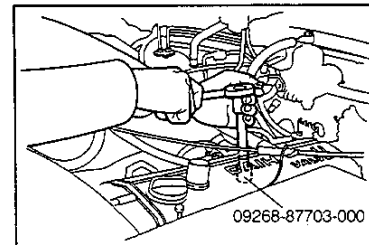

09268-87703-000

WFES0-IG026

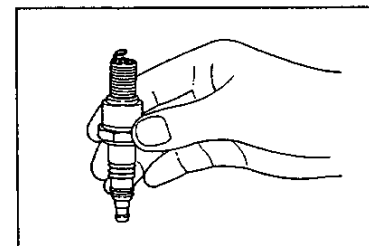

WFES0-IG027

## IGNITION SYSTEM

5. Inspection of electrode gap  
Measure the electrode gap, using a plug gap gauge.  
Electrode Gap: 1.0 - 1.1 mm

If the electrode gap of a used spark plug is not within the specification, replace the spark plug with a new one.  
If the electrode gap of a new spark plug is not within the specification, adjust the gap by bending the base of the ground electrode, being careful not to touch the tip.

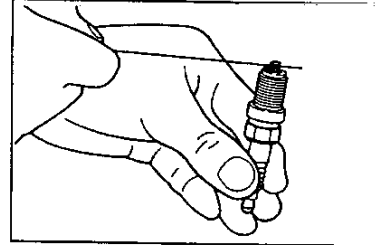

WFES0-IG022

6. Cleaning of spark plug  
If the electrode has traces of wet carbon, dry the electrode and clean it with a spark plug cleaner.  
Air Pressure: Not to exceed 588.4 kPa (6 kgf/cm<sup>2</sup>)  
Duration: Less than 20 seconds

**NOTE:**

- If there are traces of oil, remove it with gasoline before the spark plug is cleaned by the spark plug cleaner.

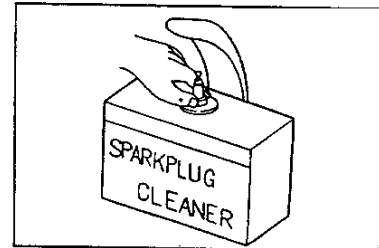

WFES0-IG025

7. Inspection of spark plug insulation resistance  
More than 20 MΩ

If the insulation resistance is less than the specified value, replace the spark plug.

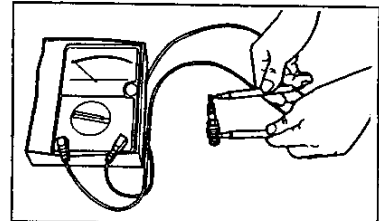

WFES0-IG030

8. Installation of spark plug  
Install the spark plugs. Tighten them to the specified torque, using the following SST.  
SST: 09268-87703-000  
Tightening Torque: 14.7 - 21.6 N·m (1.5 - 2.2 kgf·m)

**NOTE:**

- Since the insulator strength of a small spark plug is comparatively smaller than that of regular spark plugs, when tightening, be sure to use the tool exclusively used for this application. Also, when tightening, never use the wrench in a crooked way.

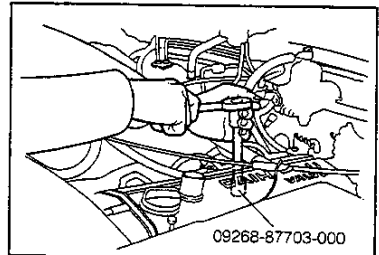

09268-87703-000

WFES0-IG031

9. Connect the spark plug wire to the spark plug.

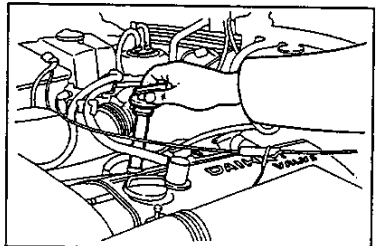

WNUEB-IG032

## IGNITION SYSTEM

### INSPECTION OF IGNITION COIL

1. Disconnect the resistive cord from the ignition coil.

**NOTE:**

- Do not hold the cord portion during disconnection. Be sure to disconnect the cord by holding the rubber boot.

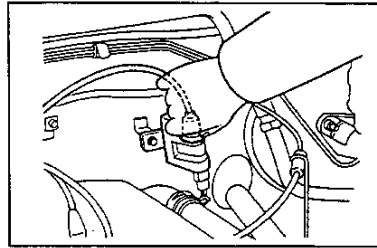

2. Disconnect the coil wire connector from the ignition coil.

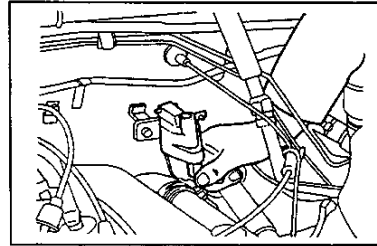

3. Check of primary coil resistance

Measure the resistance of the primary coil across the ignition coil terminals, as shown in the right figure.

**Primary Coil Resistance at 20°C: 1.35 - 1.65  $\Omega$**

If the measured value fails to conform to the specification, replace the ignition coil.

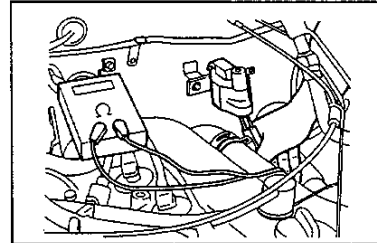

4. Check of secondary coil resistance

Measure the resistance of the secondary coil between the positive (+) terminal of the ignition coil and the resistive cord terminal, as shown in the right figure.

**Secondary Coil Resistance at 20°C: 22 - 30 k $\Omega$**

If the measured value fails to conform to the specification, replace the ignition coil.

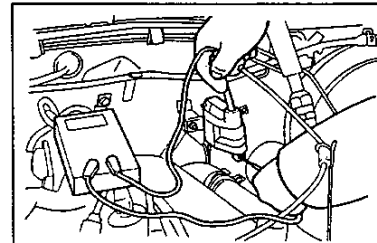

5. Check of insulation resistance

Measure the insulation resistance between positive (+) terminal of the ignition coil and coil case.

**Insulation Resistance: More than 1000 k $\Omega$   
(Infinity)**

If the measured value fails to conform to the specification, replace the ignition coil.

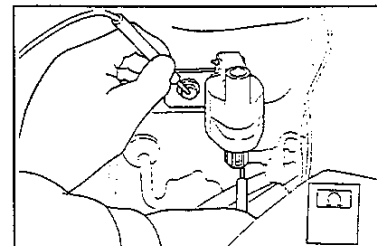

**DISTRIBUTOR COMPONENTS**

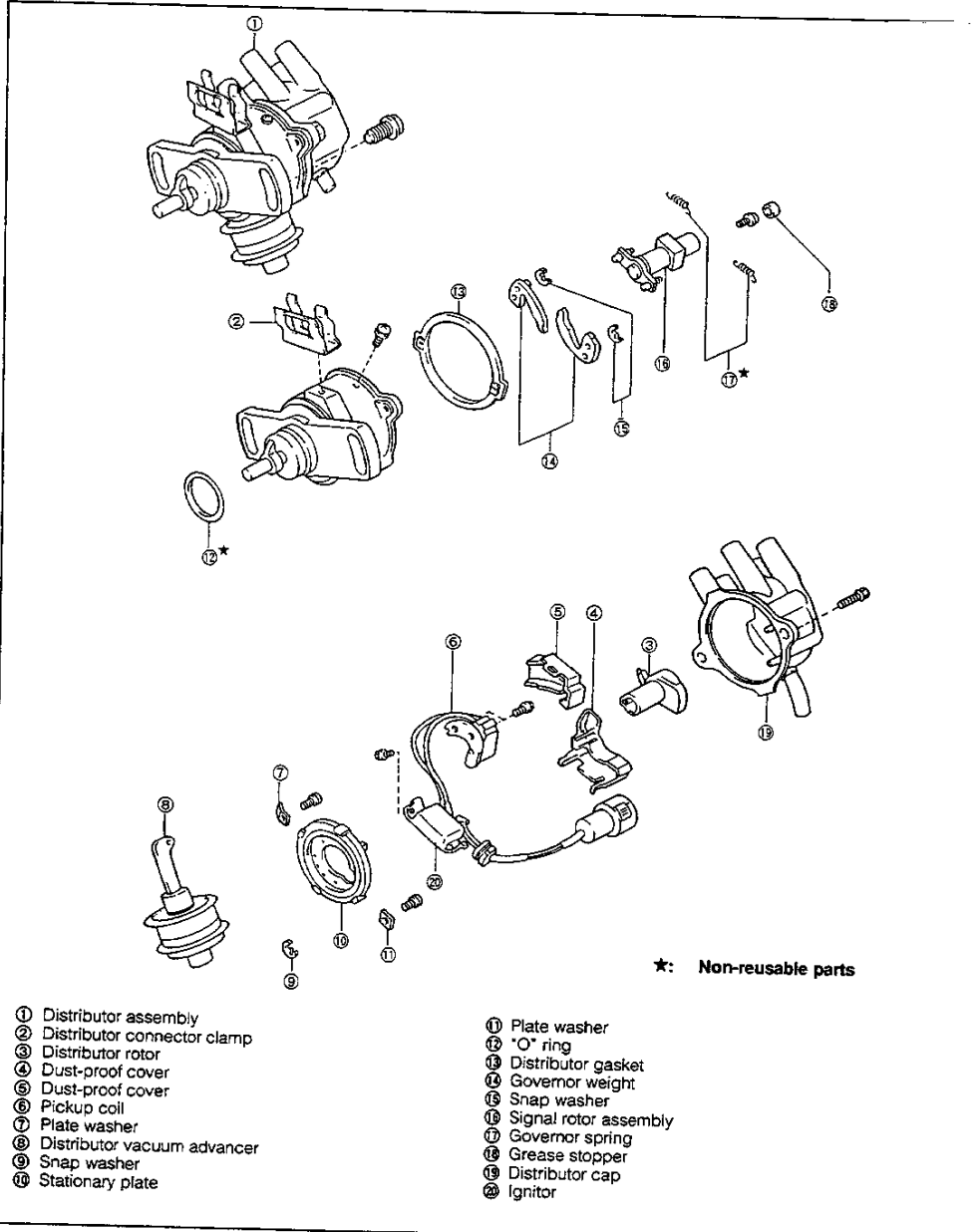

★: Non-reusable parts

- ① Distributor assembly
- ② Distributor connector clamp
- ③ Distributor rotor
- ④ Dust-proof cover
- ⑤ Dust-proof cover
- ⑥ Pickup coil
- ⑦ Plate washer
- ⑧ Distributor vacuum advancer
- ⑨ Snap washer
- ⑩ Stationary plate

- ⑪ Plate washer
- ⑫ "O" ring
- ⑬ Distributor gasket
- ⑭ Governor weight
- ⑮ Snap washer
- ⑯ Signal rotor assembly
- ⑰ Governor spring
- ⑱ Grease stopper
- ⑲ Distributor cap
- ⑳ Ignitor

WFE90-IG038

## IGNITION SYSTEM

### INSPECTION OF DISTRIBUTOR

#### Check and adjustment of air gap

1. Remove the spark plug wires from the distributor cap.
2. Remove the distributor. (See page IG-18.)
3. Remove the distributor cap.

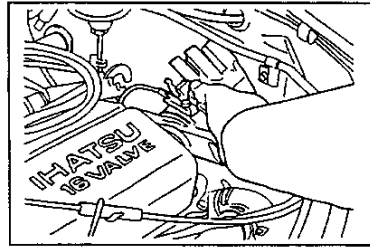

WFE90-IG036

4. Check of vacuum advancer  
Apply a negative pressure of more than 20 kPa (150 mmHg).  
Ensure that vacuum advancer operates.  
Repair or replace the vacuum advancer, as required, if it will not operate.

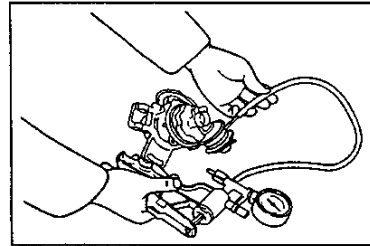

WFE90-IG040

5. Check of governor advancer
  - (1) Turn the rotor counterclockwise and release it. Ensure that the rotor returns clockwise rapidly.  
Repair or replace the rotor, as required, if it will not return to the original position.
  - (2) Check the rotor for excessive play.
6. Pull out the rotor.

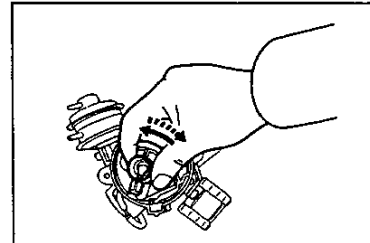

WFE90-IG041

7. Turn the crankshaft until the signal generator faces toward the signal rotor.
8. At all four points check to see if the air gap between the signal generator and the signal rotor conforms to the specified value.  
**Specified Gap: 0.2 - 0.4 mm**

If the air gap fails to conform to the specified value, adjust the air gap.

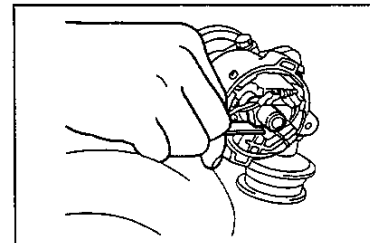

WFE90-IG042

9. Adjustment of air gap
  - (1) Remove the lock, being very careful not to damage the ignitor dust-proof cover. Then, pull out the wire from the signal generator, making sure that no damage is made to the wire.
  - (2) From the dust-proof cover, remove the wire lid from the signal generator. Be very careful not to damage the wire.

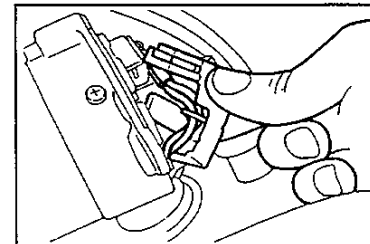

WFE90-IG043



## IGNITION SYSTEM

- (3) Loosen the attaching screws of the signal generator.
- (4) Adjust the air gap between the signal generator and the signal rotor to the specified value.

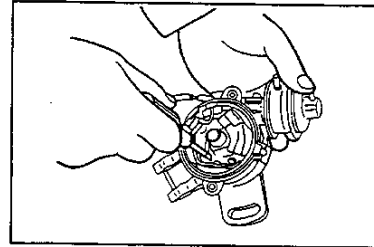

WFES0-IG044

- (5) Tighten the attaching screws of the signal generator.  
Tightening Torque: 1.2 - 2.0 N·m (12 - 21 kgf-cm)

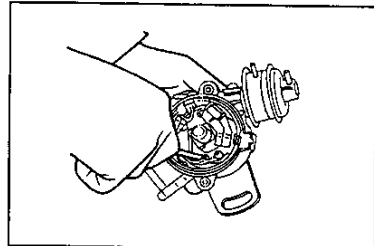

WFES0-IG045

- (6) Check the air gap.  
Specified Value: 0.2 - 0.4 mm

If the air gap fails to conform to the specified value, adjust the air gap again.

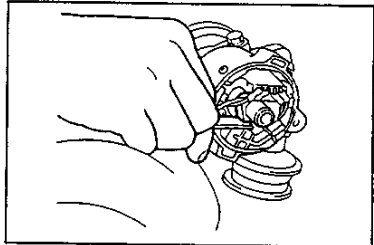

WFES0-IG046

10. Install the wire from the signal generator to dust proof cover.
11. Install the dust proof cover to the ignitor.
12. Install the rotor.
13. Check the distributor cap gasket for cracks or damage.  
If it exhibits cracks or damage, replace the gasket with new one.

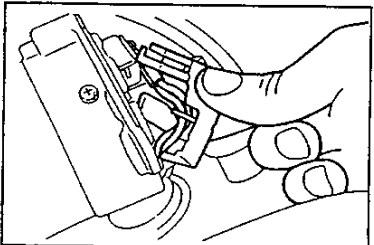

WFES0-IG047

14. Install the distributor cap gasket and distributor cap.
15. Install the distributor to the cylinder head.  
(See page IG-27.)
16. Connect the distributor connector.
17. Connect the resistive cord to the distributor cap.
18. Perform the ignition timing adjustment.  
(See page IG-28.)

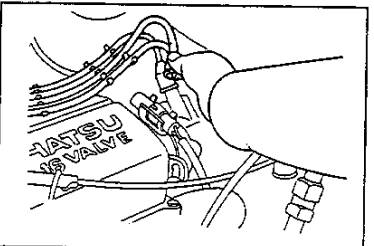

WFES0-IG048

## IGNITION SYSTEM

### REMOVAL OF DISTRIBUTOR

1. Disconnect the battery ground cable from the negative (-) terminal of the battery.
2. Disconnect the spark plug wires from the distributor cap.  
**NOTE:**
  - Do not hold the cord during disconnection. Be sure to disconnect the cord by holding the rubber boot.

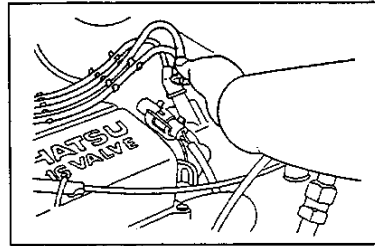

3. Disconnect the distributor connector.
4. Disconnect the vacuum advancer hoses.  
**NOTE:**
  - Prior to the disconnection, put a tag so that the original installation position may be identified readily.
5. Remove the distributor set bolt.

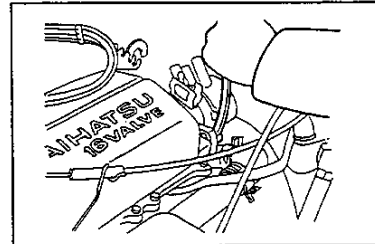

6. Pull out the distributor from the cylinder head.  
**NOTE:**
  - Since the engine oil flows out, insert a suitable cloth under the distributor connecting section.

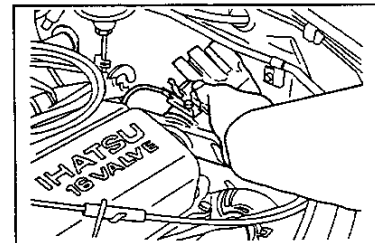

### DISASSEMBLY OF DISTRIBUTOR

1. Remove the "O" ring from the distributor housing.
2. Remove the distributor cap from the distributor housing.

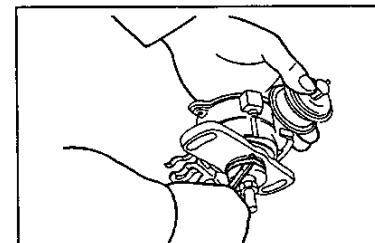

3. Remove the distributor cap gasket.

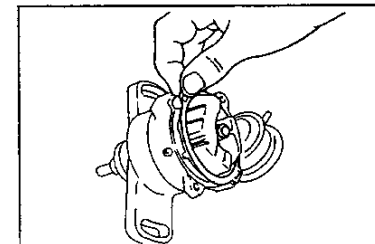

## IGNITION SYSTEM

4. Remove the rotor.

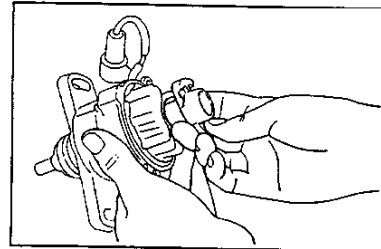

5. Remove the ignitor by removing the two attaching screws.  
**CAUTION:**
- Be very careful not to damage the wire.

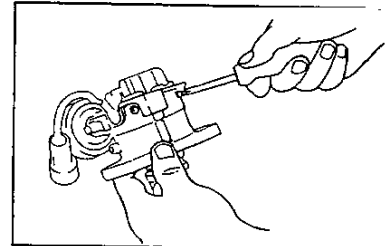

6. Remove the signal generator by removing the two attaching screws.

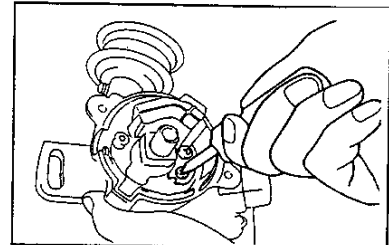

7. Remove the snap washer of the vacuum advancer.

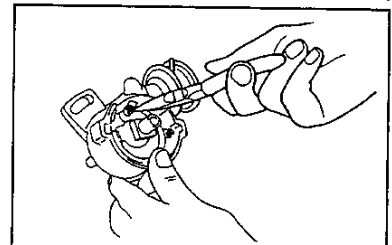

8. Remove the attaching screw of the vacuum advancer.

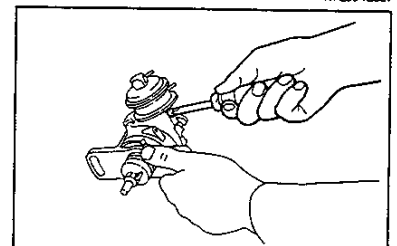

## IGNITION SYSTEM

9. Remove the vacuum advancer from the pin of the stationary plate.  
Pull out the vacuum advancer from the distributor housing.

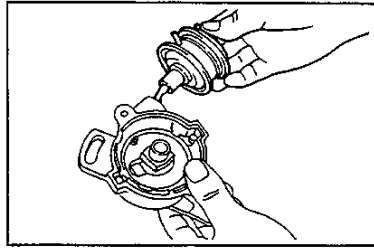

10. Remove the two attaching screws and plate of the distributor stationary plate.

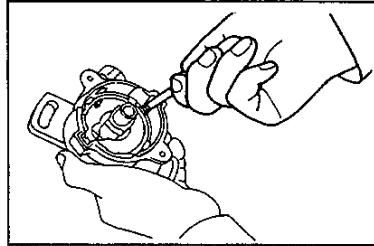

11. Remove the stationary plate from the distributor housing.

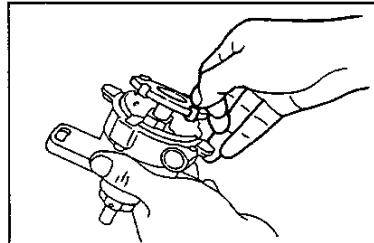

12. Remove the governor springs.

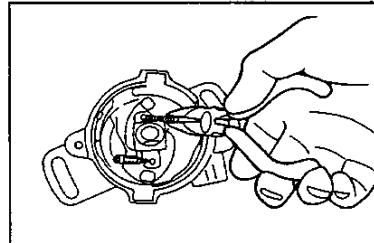

13. Removal of signal rotor assembly  
(1) Remove the grease stopper.

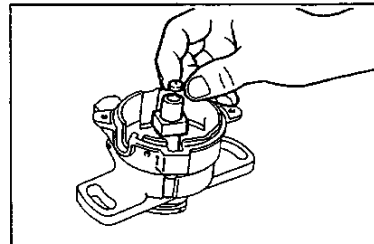

## IGNITION SYSTEM

- (2) Remove the attaching screw of the signal rotor assembly.
- (3) Remove the signal rotor assembly.

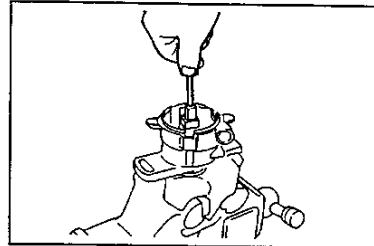

WPES0-IG064

14. Remove the snap washer of the governor weight.  
Remove the governor weight.

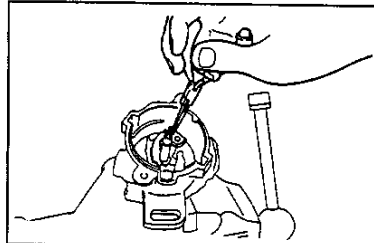

WPES0-IG065

### INSPECTION OF DISTRIBUTOR COMPONENTS

1. Inspect the stationary plate.  
Check to see if the stationary inner plate rotates on the outer plate smoothly.  
If the inner plate will not rotate smoothly, replace the stationary plate.

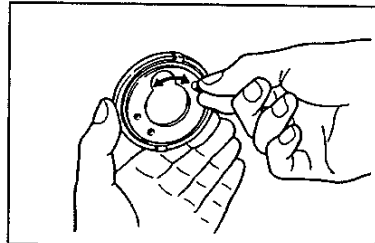

WPES0-IG066

2. Inspection of distributor housing
  - (1) Check to see if the governor shaft rotates smoothly.  
If it will not rotate smoothly, replace the distributor housing.

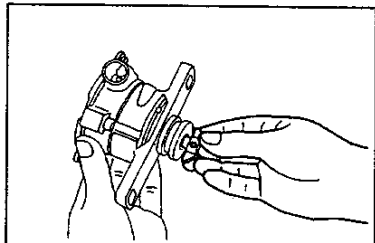

WPES0-IG067

- (2) Check the sliding section of the governor weight for wear or damage.  
Replace the distributor housing if it exhibits wear or damage.

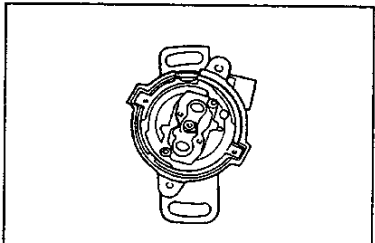

WPES0-IG068

## IGNITION SYSTEM

- (3) Check the coupling section of the governor shaft for wear or damage. Also, check to see if any excessive play is present in the turning direction.  
Replace the distributor housing if it exhibits wear, damage and/or excessive play in the turning direction.

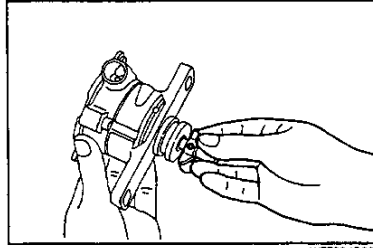

WF890-IG065

3. Inspection of governor weight for damage or wear  
(1) Visually inspect the governor weight for damage or wear.  
Replace the governor weight if it exhibits damage or wear.

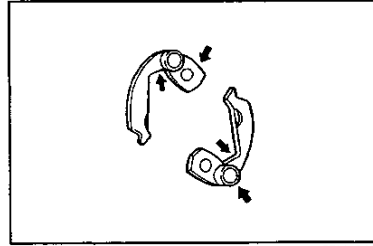

WF890-IG070

- (2) Install the governor weight to the governor shaft.  
Check to see if any excessive play is present.  
If excessive play is present, replace the governor weight and/or distributor housing, as required.

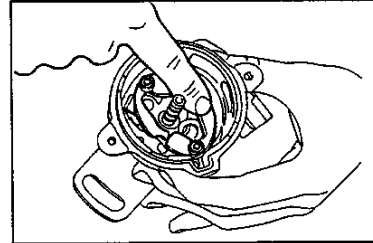

WF890-IG071

4. Inspection of signal rotor assembly  
(1) Visually inspect the signal rotor for damage.  
Replace the signal rotor assembly if it exhibits damage.  
(2) Check the pin section of the signal rotor assembly for wear or damage.  
Replace the signal rotor assembly if the pin section exhibits wear or damage.

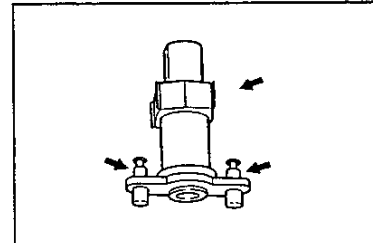

WF890-IG072

- (3) Install the signal rotor assembly to the governor shaft temporarily. Check to see if the signal rotor is tilted.  
Replace the signal rotor assembly and/or distributor housing if it is tilted.

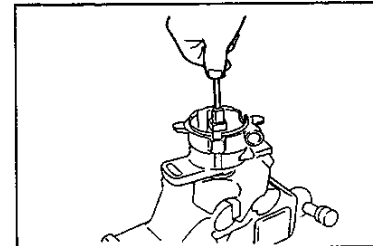

WF890-IG073

## IGNITION SYSTEM

### 5. Inspection of vacuum advancer

- (1) Gradually apply a negative pressure to the main diaphragm of the vacuum advancer. Ensure that the rod of the vacuum advancer is drawn into the diaphragm room side, corresponding to the negative pressure. Replace the vacuum advancer if the rod will not be drawn.

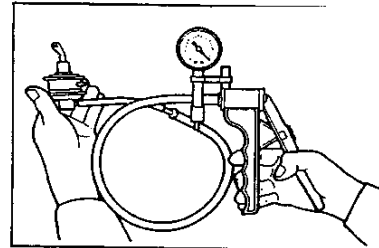

WFES0-IG01

- (2) Gradually apply a negative pressure to the sub diaphragm of the vacuum advancer. Ensure that the rod of the vacuum advancer is drawn into the diaphragm room side, corresponding to the negative pressure. Replace the vacuum advancer if the rod will not be drawn.

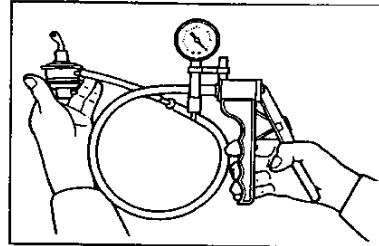

WFES0-IG01

### 6. Inspection of rotor

Check the center carbon contacting surface and electrode for damage, such as wear, electrolytic corrosion and cracks.

If the surface or electrode exhibits damage, replace the rotor, as required.

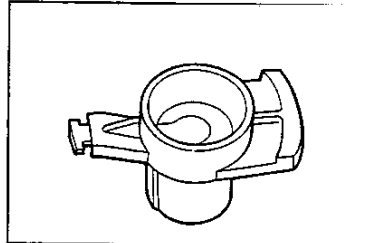

WFES0-IG01

### 7. Inspection of distributor cap

Check the distributor cap for cracks. Also, check the electrode and center carbon for damage, such as wear.

Replace the distributor cap if the cap, electrode or carbon exhibits damage.

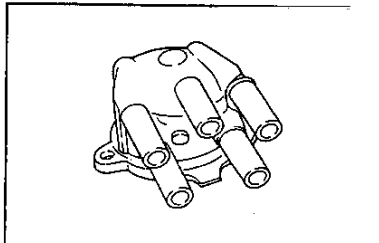

WFES0-IG01

## ASSEMBLY OF DISTRIBUTOR

1. Install the governor weight to the distributor housing. Install the snap washer.

#### NOTE:

- Thinly apply high-temperature grease to the sliding section.

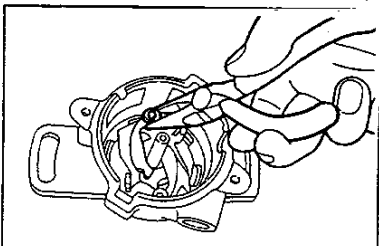

WFES0-IG078

## IGNITION SYSTEM

### 2. Installation of signal rotor assembly

- (1) Thinly apply high-temperature grease to the sliding section of the signal rotor assembly. Install the signal rotor assembly to the distributor housing.

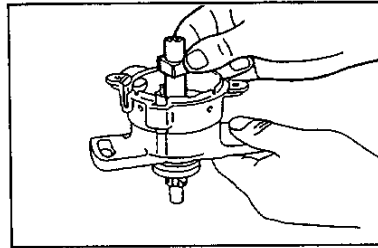

WFES0-IG075

- (2) Tighten the attaching screw.

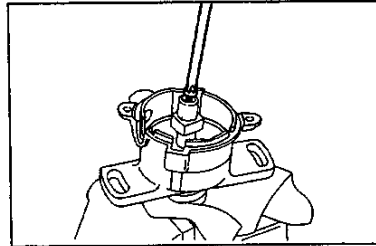

WFES0-IG080

- (3) Pack high-temperature grease in the signal rotor assembly.

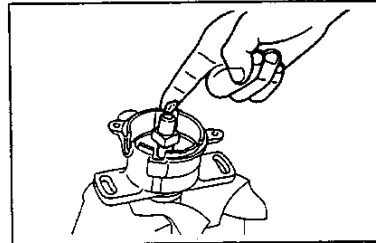

WFES0-IG081

- (4) Press the grease stopper by your hand.

**NOTE:**

- Wipe off any excess grease which has oozed out.

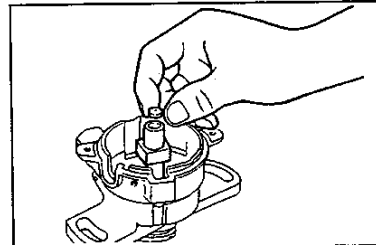

WFES0-IG082

3. Install the new governor spring to the distributor.

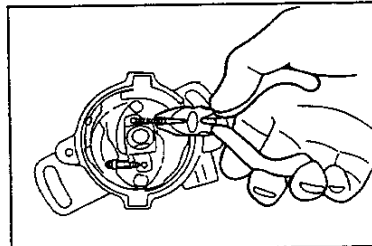

WFES0-IG083



## IGNITION SYSTEM

4. Assemble the stationary plate, lining up the cut-out section of the distributor housing.

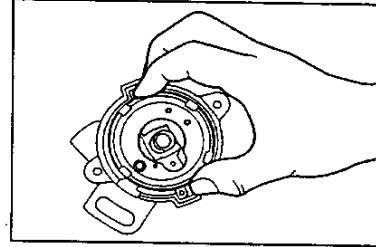

WFES0-IG084

5. Secure the stationary plate installation seat and stationary plate with the screws.

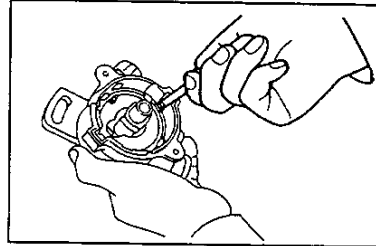

WFES0-IG085

6. Insert the vacuum advancer into the distributor housing. Connect it to the pin of the stationary inner plate.

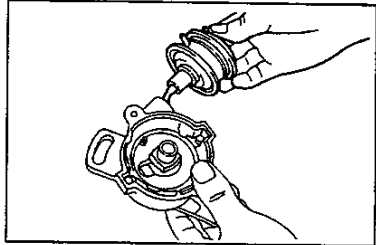

WFES0-IG086

7. Align the screw hole of the vacuum advancer with the screw hole of the distributor housing. Install and tighten the attaching screw.

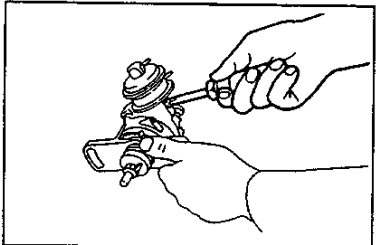

WFES0-IG087

8. Attach the snap washer of the vacuum advancer.

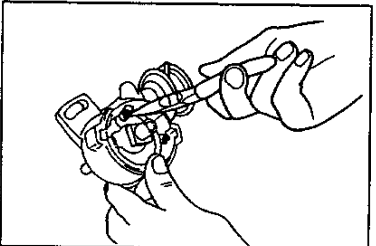

WFES0-IG088

## IGNITION SYSTEM

9. Installation of signal generator

Install the signal generator to the stationary plate. Adjust the air gap in such a way that the air gap in relation to the signal rotor is 0.2 - 0.4 mm.

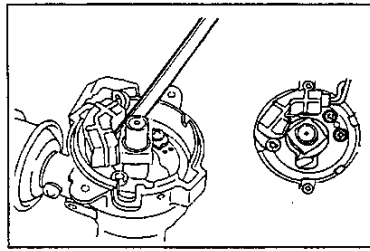

WFE90-IG089

10. Install the ignitor to the distributor with the screw.

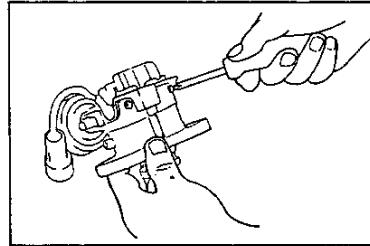

WFE90-IG090

11. Attach the rotor.

12. Install a distributor cap gasket to distributor body.

**NOTE:**

- If the gasket is damaged, replace it with a new one.

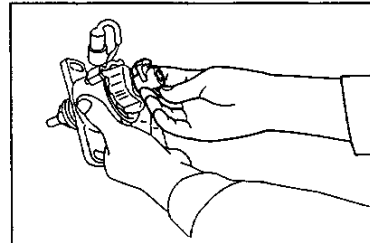

WFE90-IG091

13. Install the distributor cap to the distributor housing.

Also, tighten the clamp of the distributor connector, too, at the vacuum advancer side of the distributor cap attaching screw.

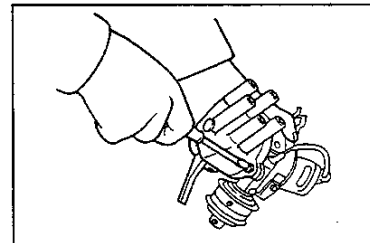

WFE90-IG092

14. Install a new "O" ring to the distributor housing.

**NOTE:**

- Be very careful not to damage the "O" ring.
- When the distributor is pulled from the cylinder head once, be sure to replace the "O" ring with a new one.

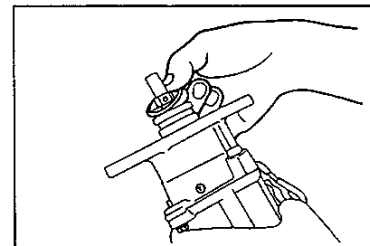

WFE90-IG093

**INSTALLATION OF DISTRIBUTOR**

1. Turn the crankshaft, until the No.1 cylinder (at the timing belt side) comes at the top dead center at the end of the compression stroke.  
Under this conditions, the crankshaft timing marks should be aligned and the valve rocker arms should be inoperative (the rocker arms actuated by the camshaft are not pushing down the valves).

**NOTE:**

- Ensure that the No.1 rocker arms are not operating. This check can be performed by moving the rocker arms with your fingers after removing the oil filler cap.

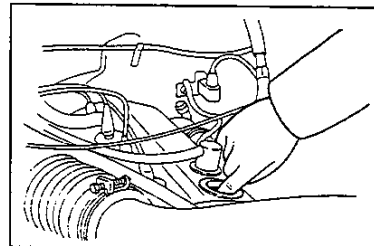
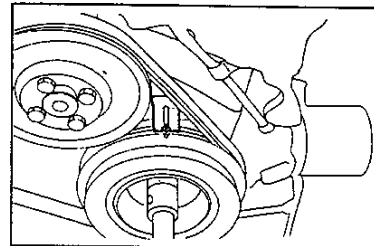

2. Align the cut-out section of the distributor housing with the cut-out section of the coupling.

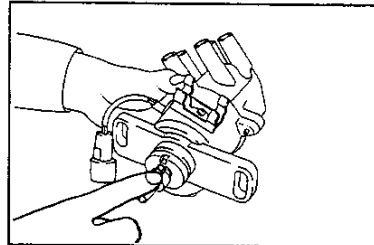

3. Insert the distributor into the cylinder head. At this time, ensure that the distributor attaching hole of the cylinder head comes at the center of the elongated hole for the distributor bolt.

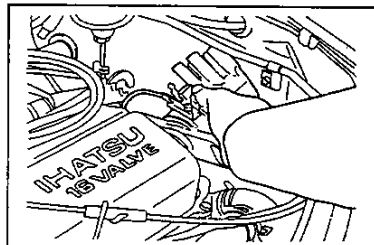

4. Tighten the distributor two attaching bolts temporarily.

**NOTE:**

- The final tightening should be performed after the check and adjustment of the ignition timing have been completed.

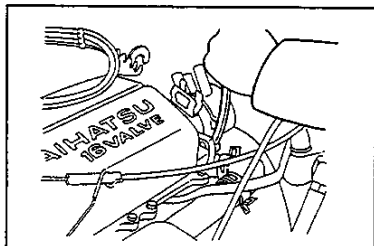

## IGNITION SYSTEM

5. Connect the vacuum advancer hoses.
6. Connect the distributor connector. Install it to the clamp.
7. Connect the spark plug wires to the distributor cap.

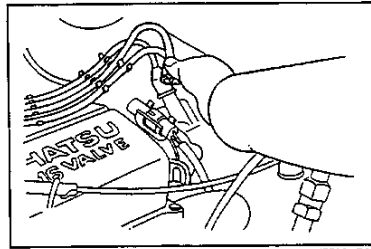

WF90-IG099

8. Install the clamp to the spark plug wire.

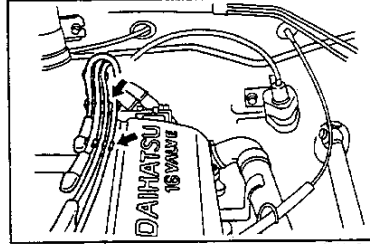

WF90-IG100

9. Connect the ground cable terminal to the negative (-) terminal of the battery.

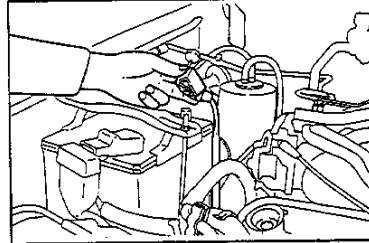

WF90-IG101

10. Check and adjustment of ignition timing
    - (1) Start the engine. Warm up the engine.
    - (2) Connection of tachometer and timing light
      - ① Connect the cable for measuring tachometer use to the following SST.
- SST: 09991-87703-000

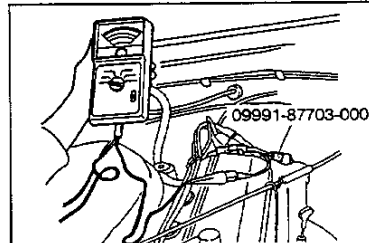

WF90-IG102

### CAUTION:

- Never allow the tachometer terminal to touch ground. It could result in damage to ignitor and/or ignition coil.
- As some tachometers are not compatible with this ignition system, it is recommended to confirm the compatibility of your unit before using.

## IGNITION SYSTEM

- ② Connect the timing light to spark plug wire of the No. 1 cylinder (at the timing belt side).

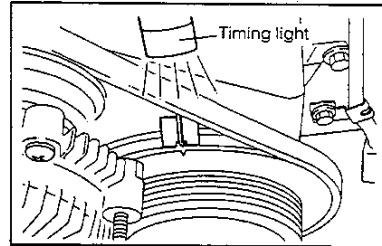

WFES0-IG103

- (3) Disconnect the vacuum hose at the sub side of the vacuum advancer of the distributor. Plug the disconnected vacuum hose, using the following SST.  
SST: 09258-00030-000

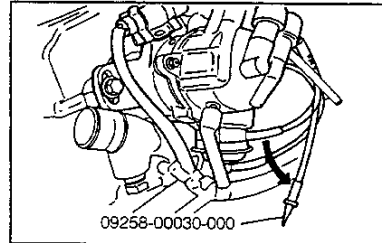

WFES0-IG104

- (4) Ensure that the engine revolution is under 1000 rpm and stable.  
If the engine revolution exceeds 1000 rpm or is unstable, adjust the engine idle speed.

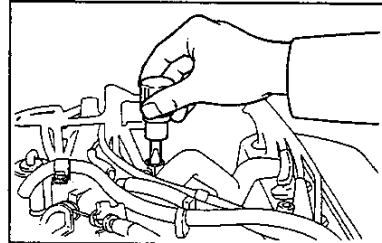

WFES0-IG105

- (5) Check to see if the ignition timing mark of the crankshaft pulley is aligned with the indicator of the timing belt cover.  
Tighten the distributor attaching bolts to the specified torque if the ignition timing mark is aligned with the indicator.

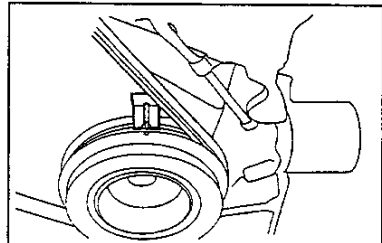

WFES0-IG106

- (6) Loosen the distributor attaching bolts. Adjust the distributor installation position, until the ignition timing mark of the crankshaft pulley is aligned with the indicator of the timing belt cover.

### Reference

- If the distributor is turned clockwise, the timing will be advanced. Conversely, if the distributor is turned counterclockwise, the timing will be retarded.

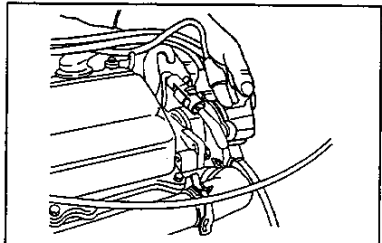

WFES0-IG107

## IGNITION SYSTEM

- (7) Tighten the distributor attaching bolts to the specified torque, making sure that the ignition timing is not disturbed.

Tightening Torque: 14.7 - 21.6 N·m (1.5 - 2.2 kgf·m)

11. Connect the vacuum hose at the sub side of the vacuum advancer to the vacuum advancer.

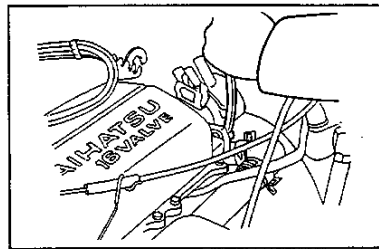

WF890-IG108

12. Adjust the engine idle speed.

(See page EM-23.)

13. Check the oil level.

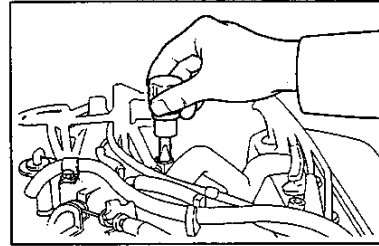

(See page LU-9.)



WF890-IG109

## IGNITION SYSTEM

### SST [Special Service Tools]

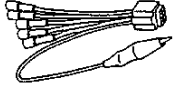
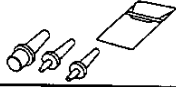
Shape	Part No. and Name	Purpose	Remarks
	09268-87703-000 Plug wrench	Removal and installation of spark plugs	
	09991-87703-000 Tacho pulse pickup wire	Connecting engine tachometer	
	09991-87702-000 Engine control system inspection sub harness	<ul style="list-style-type: none"> <li>Shorting terminal T</li> <li>Actuating fuel pump etc.</li> </ul>	Only HD-E engine
	09258-00030-000 Plug set	Plugging rubber hoses	

WFE90-IG110

### TIGHTENING TORQUE

Tightening component	Tightening torque			Remarks
	N·m	kgf·m	ft·lb	
Cylinder head × Spark plug	14.7 - 21.6	1.5 - 2.2	10.8 - 15.9	Dry
Cylinder head × Distributor	14.7 - 21.6	1.5 - 2.2	10.8 - 15.9	Dry

WFE90-IG111

### SPECIFICATION

Spark plugs	Manufacture	NIPPONDENSO	NGK	CHAMPION
	Type	K20PR-U11 K22PR-U11	BKR6E-11 BKR7E-11	RC9YC4 RC7YC4
	Thread	M14 × 1.25		
	Spark plug gap	mm	1.0 - 1.1	
Ignition timing	No sub vacuum timing advance takes place. (Engine revolution must be stable at 1000 rpm or less.)	BTDC 3 ± 2°		
Spark plug wire	Resistance	Maximum	15 kΩ per cord	
Distributor	Air gap between signal rotor and signal generator	0.2 - 0.4 mm		
Ignition coil	Primary coil	1.35 - 1.65 Ω at 20°C		
	Secondary coil	22 - 30 kΩ at 20°C		

WFE90-IG112